

TECHNICAL BULLETIN

Wood Pole Design Considerations

Prepared by:

W. Richard Lovelace

Executive Consultant

Hi-Line Engineering

a GDS Company



About NAWPC

The North American Wood Pole Council (NAWPC) is a federation of three organizations representing the wood preserving industry in the U.S. and Canada. These organizations provide a variety of services to support the use of preservative-treated wood poles to carry power and communications to consumers.

The three organization are:

Western Wood Preservers Institute

With headquarters in Vancouver, Wash., WWPI is a non-profit trade association founded in 1947. WWPI serves the interests of the preserved wood industry in the 17 western states, Alberta, British Columbia and Mexico so that renewable resources exposed to the elements can maintain favorable use in aquatic, building, commercial and utility applications. WWPI works with federal, state and local agencies, as well as designers, contractors, utilities and other users over the entire preserved wood life cycle, ensuring that these products are used in a safe, responsible and environmentally friendly manner.

Southern Pressure Treaters' Association

SPTA was chartered in New Orleans in 1954 and its members supply vital wood components for America's infrastructure. These include pressure treated wood poles and wood crossarms, and pressure treated timber piles, which continue to be the mainstay of foundation systems for manufacturing plants, airports, commercial buildings, processing facilities, homes, piers, wharfs, bulkheads or simple boat docks. The membership of SPTA is composed of producers of industrial treated wood products, suppliers of AWPA-approved industrial preservatives and preservative components, distributors, engineers, manufacturers, academia, inspection agencies and producers of untreated wood products.

Wood Preservation Canada

WPC is the industry association that represents the treated wood industry in Canada. WPC operates under Federal Charter and serves as a forum for those concerned with all phases of the pressure treated wood industry, including research, production, handling, use and the environment. WPC is dedicated to promoting and supporting a stronger Canadian wood treating industry; informing the public on the benefits to be gained from the use of quality wood products; and preserving the integrity of the environment through the promotion of responsible stewardship of our resources.

Wood Pole Design Considerations

Prepared by
W. Richard Lovelace
Executive Consultant
Hi-Line Engineering
a GDS Company

Introduction

Since the beginning of electrification more than a century ago, the wood pole has been at the heart of providing electrical service to the people of North America. Transmission and distribution lines deliver power to large cities, small towns and remote outposts.

Due to the continued advancements in wood preserving and engineering technology combined with its natural benefits and economics, the wood pole remains the foundation of power distribution in the 21st century. With more than 130 million wood poles in service and millions of new wood poles installed each year, it is little wonder that wood remains the material of choice for poles used by the utility industry.

Proper line design, pole selection and installation are the keys to the successful use of the wood pole. As an electrical distribution design and professional training consulting firm, Hi-Line Engineering is pleased to provide its perspective on the design and use of the wood pole.

Basic Structure Design

Application of Structure Loads

The fundamental building block in overhead electrical distribution line construction is the wood

pole. It is abundant in nature, renewable, easy to handle, an excellent insulator, cost effective and environmentally preferred.

A finished wood utility pole can be made from several types of trees. Common species of wood poles include Southern Pine, Douglas fir, Western Red Cedar and Northern Red Pine. The trees are harvested, milled to a length and class, and pressure treated with a preservative.

Utility engineers, staking technicians and linemen must select the correct length and class of poles to safely support the power line conductors and equipment.

This bulletin will provide insight into the basics of choosing a pole that will provide adequate strength to support the conductors used in electrical distribution pole-line construction. All rules, calculations and parameters are based on the 2017 edition of the *National Electrical Safety Code* and the *American National Standard for Wood Utility Products ANSI O5.1-2015*.

An electrical distribution pole must support conductor vertical, longitudinal and transverse loads caused by weight, wind and wire tension under specified design loading conditions. Table 1 defines the different type loads, the direction of the force and the causal agent.

Table 1

Physical loads affecting wood poles		
<i>Type Load</i>	<i>Direction of Force</i>	<i>Caused By</i>
Vertical	In line with the axis of the pole or column	Weight of the attached equipment and ice loaded conductors plus the vertical component of guy tension
Longitudinal	Parallel to the direction or run of the line	Tension in the wire dependent on the sag and tension values used during installation
Transverse	Perpendicular to the direction or run of the line	Wind blowing on the bare or ice laden conductors and pole plus the tension produced by line angles

Usually, there is only one direction of loading that dictates the minimum class of a wood pole that will adequately support all the applicable loads. This is called the *direction of critical loading*.

For tangent poles and small line angle poles, the direction of critical loading for conductors is transverse. The designer must resolve the critical load, then calculate the pole strength needed to support the application.

This bulletin will discuss transverse loading of conductors on tangent and small line angle structures.

Ice and wind conditions vary depending on the area of the U.S. where the pole-line is located. The *National Electrical Safety Code* (NESC) divides the U.S. into the three primary loading districts based on the expected ice and wind conditions over time. They are heavy, medium and light, and are shown in Figure 250-1 in the NESC.

For each loading district, the NESC describes specific wind and ice loads that distribution pole lines must support. Table 2 summarizes these values. A wood pole must have sufficient natural fiber mass and strength to support the conductors and equipment produced by the specified design conditions.

Table 2

NESC loading districts, conditions			
Loading District	Temperature (°F)	Radial thickness of ice (in.)	Horizontal wind pressure (lb/ft. ²)
Heavy	0	0.50	4
Medium	15	0.25	4
Light	30	0.00	9

Based on Table 250-1 of the 2017 Edition of the National Electrical Safety Code

Transverse loads are caused by wind blowing on the ice-laden conductors in the medium and heavy loading districts and the bare conductors in the light loading district. The first problem facing the line designer is to select a pole class that will adequately support tangent (straight line) spans of wire in a line section for the applicable NESC loading district.

Initially, the designer must understand how to select a pole length and class to support a given set of conditions. For designing large line sections, the designer should determine the maximum wind span that a given pole length and class will support.

A tangent and small line angle (5° or less) wood pole structure will be evaluated in this bulletin. These two types of structures will comprise most of the non-guyed poles for a typical distribution line. For medium to large line angle or full tension dead-end wood poles, the conductors must be supported with guy wires and anchors.

Selecting a Tangent Pole Class

The first step in choosing a pole length and class to support a designated set of conductors for a tangent line section is to calculate the transverse ice and wind load on the wire. To determine the amount of transverse load on a span of conductor, the load is usually evaluated for 1-ft. of a specified conductor and then applied to the total wind span length.

Calculate the transverse load for 1-ft. of conductor using the following procedure:

Figure 1

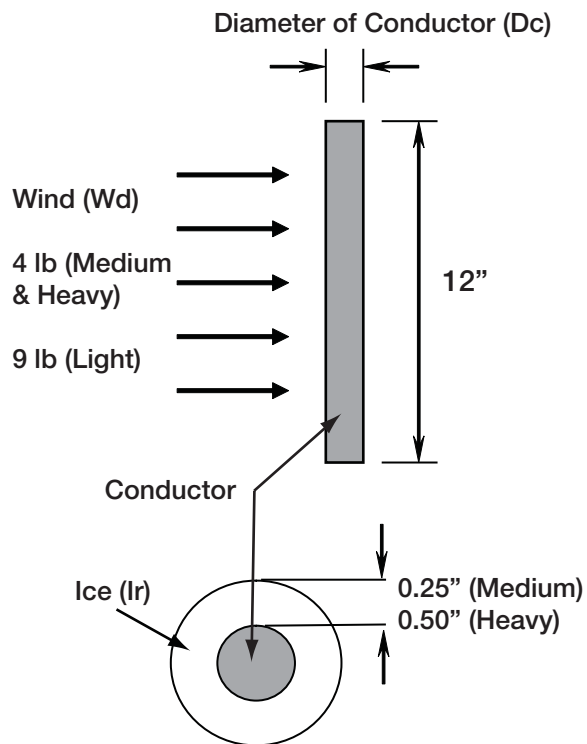

$$W_c = \frac{W_d [D_c + 2 (I_r)]}{12}$$

- W_c = Transverse wind load for 1-ft of conductor in lbs/ft
- W_d = NESC district wind loading in lbs/ft²
- D_c = Diameter of conductor in inches
- I_r = Radial thickness of ice in inches

Table 3

Transverse wind load and tensile strength for specified conductors						
<i>Conductor Physical Data</i>				<i>Transverse Wind Load (Wc)</i>		
<i>Code Name</i>	<i>Size & Strand</i>	<i>Diameter</i>	<i>Tensile Strength</i>	<i>Light (lbs/ft.)</i>	<i>Medium (lbs/ft.)</i>	<i>Heavy (lbs/ft.)</i>
Sparrow	2 ACSR, 6/1	0.316 in.	2,850 lbs.	0.2370	0.2720	0.4387
Raven	1/0 ACSR 6/1	0.398 in.	4,380 lbs.	0.2985	0.2993	0.4660
Penguin	4/0 ACSR 6/1	0.563 in.	8,350 lbs.	0.4223	0.3543	0.5210
Merlin	336 ACSR 18/1	0.684 in.	8,680 lbs.	0.5130	0.3947	0.5613

Using the equation in Figure 1, transverse wind loads can be calculated for any series of conductors. Values for four typical distribution conductors are shown in Table 3.

To choose a tangent pole to adequately support a set of conductors, the designer must determine the resisting moment of a selected length and class pole. The *resisting moment* is the amount of force a pole can withstand at the point of maximum stress before it breaks.

The resisting moment is calculated based on the fiber strength of the wood species and the circumference of the pole at the ground-line and the pole top. The pole classes in ANSI O5.1 are determined from the circumference of the pole at the ANSI classification point (6-ft. from the butt) and at the pole top.

Figure 2

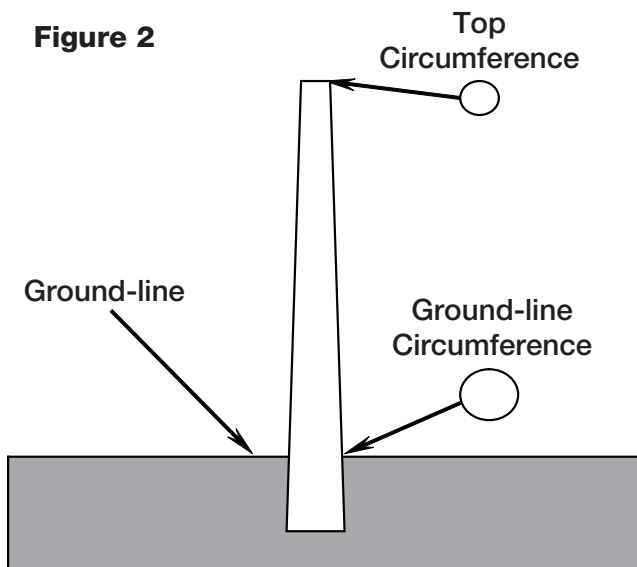

The 2017 NESC requires that wood structures be designed to withstand the specified loads in Rule 252 multiplied by the load factors in Table 253-1 without exceeding the permitted stress level at the

point of maximum stress. The 2017 NESC refers to the 2015 edition of ANSI O5.1 for resolution of the point of maximum stress along the pole column above grade.

In the 2017 NESC, Rule 261A2a, EXCEPTION 1 allows for non-guyed naturally grown wood poles 55-ft. or less in length for the point of maximum stress to be evaluated at the ground-line. This bulletin will address distribution poles 55-ft. and less in length only.

The fiber strength is dependent upon the tree species from which the pole is produced. Table 4 shows various tree species and the fiber strength of each.

Table 4

Wood fiber strength	
<i>Species</i>	<i>Fiber Strength</i>
Southern Pine	8,000 psi
Douglas fir	8,000 psi
Northern Red Pine	6,600 psi
Ponderosa Pine	6,000 psi
Western Red Cedar	6,000 psi
Northern White Cedar	4,000 psi

The resisting moment of a wood pole is calculated using the following equations. To fully understand the process, an example problem will be worked to develop the natural resisting moment for a 45-ft. Class 4 Southern Pine pole.

The natural resisting moment (M_{rn}) is the resisting moment of the wood pole as it comes from the pole manufacturing company.

To develop the allowable construction resisting moment, the designer must apply strength factors

from NESC Table 261-1. This will be shown later in Example 4.

- $M_{rn} = (K_r)(R_t)(C_g^3)$
- M_{rn} = Natural resisting moment (ft.-lbs.)
- K_r = Calculation constant = 0.000264
- R_t = Designated pole fiber stress for wood species (psi)
- C_g = Pole circumference at ground-line (in.)

Example 1:
Calculate the pole natural resisting moment

Pole length and class = 45'-4 Southern Pine

The ANSI O5.1 wood pole classification point is 6-ft. from the butt. Standard setting depth is 10% of the pole length plus 2-ft. A pole is a tapered cylinder and since the 45'-4 setting depth is 6.5-ft., the ground-line circumference must be adjusted for the additional 0.5-ft. of depth.

Step 1:

Calculate the pole circumference at ground-line (C_g).

$$C_g = \frac{(D_p - D_g)(C_b - C_t)}{(D_p - D_b)} + C_t$$

- C_b = Pole circumference at 6-ft. from butt = 35-in. (ANSI O5.1)
- C_t = Circumference of pole at top = 21-in. (ANSI O5.1)
- D_p = Distance from butt of pole to top of pole = 45-ft.
- D_g = Distance from pole butt to ground-line = $[10\%(45') + 2'] = [4.5 + 2] = 6.5$ -ft.
- D_b = Distance from pole butt to classification point per ANSI O5.1 = 6-ft.

$$C_g = \frac{(45' - 6.5')(35'' - 21'')}{(45' - 6')} + 21'' = 34.8205''$$

Step 2:

Calculate the natural resisting moment (M_{rn}) using the following equation. Use the above adjusted ground-line circumference (C_g) value.

- $M_{rn} = (K_r)(R_t)(C_g^3)$
- $K_r = 0.000264$
- $R_t = 8,000$ psi (Table 4)
- $C_g = 34.8205$ in. (Calculated in Step 1)
- $M_{rn} = (0.000264)(8,000)(34.8205^3) = 89,165.9$
- $M_{rn} = 89,166$ ft.-lbs.

Examples of the natural resisting moments for different tree species are shown in Table 5.

Table 5 points out that even though all the poles have approximately the same resisting moment, they vary in size at the ground-line circumference. In other words, a 45'-4 Northern White Cedar pole is significantly larger in circumference at the ground-line than a 45'-4 Southern Pine pole.

Due to the 45'-4 Northern White Cedar's lower fiber strength, more wood mass (larger circumference) is needed to provide approximately the same overall strength, or natural resisting moment, as the 45'-4 Southern Pine.

The natural resisting moment values in Table 5 also show the strength of a 45-ft. Class 4 wood pole is essentially the same for the different tree species.

A portion of the pole's inherent strength is needed to support the pole when subjected to wind. This portion of strength is called the *bending moment due to wind*. Once this value is calculated, the remainder of the pole strength can be used to support the conductors and equipment.

Table 5

Resisting moment of a 45-ft. Class 4 pole*					
Species	Fiber Strength	Circumference			Resisting Moment
		Pole Top	6-ft. from Butt	Ground-line	
Southern Pine Douglas-fir	8,000 psi	21 in.	35.0 in.	34.8205 in.	89,166 ft.-lbs.
Red Pine, Jack Pine Lodgepole Pine	6,600 psi	21 in.	37.0 in.	36.7949 in.	86,798 ft.-lbs.
Ponderosa Pine Western Red Cedar	6,000 psi	21 in.	38.5 in.	38.2756 in.	88,822 ft.-lbs.
Northern White Cedar	4,000 psi	21 in.	44.0 in.	43.7051 in.	88,158 ft.-lbs.

* Pole set at 10% plus 2-ft. deep

Figure 3

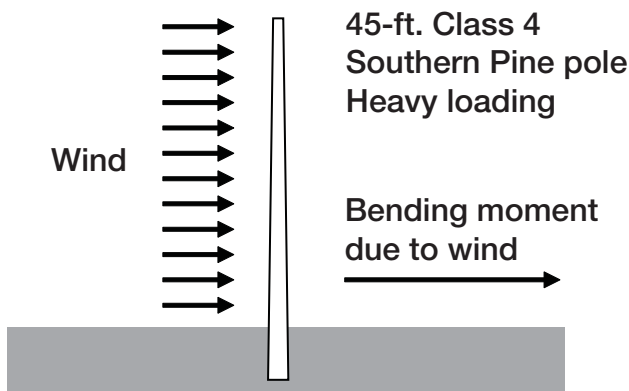

**Example 2:
Calculate the natural bending moment due to wind on the pole**

Using the following equation, calculate the natural bending moment due to wind (Mbn).

Like the natural resisting moment, the natural bending moment is for the pole as it arrives from the pole manufacturer. To develop the allowable construction bending moment due to wind on the pole, the designer must apply load factors from NESC Table 253-1 to the natural bending moment. This will be shown later in Example 4.

$$Mbn = Wd \left[\frac{(2Ct + Cg)}{Kc} \right] Hp^2$$

- Mbn = Natural bending moment due to wind blowing on the pole (ft-lbs.)
- Wd = NESC loading district horizontal wind per unit area of pole surface (lbs/ft.²)
- Ct = Circumference of pole at top (in.)
- Cg = Pole circumference at ground-line (in.)
- Kc = Calculation constant = 72π
- Hp = Height of pole above ground (ft.)

Wd = 4 lbs/ft.² (Table 2, Heavy loading, horizontal wind)

Ct = 21" (ANSI O5.1)

Cg = 34.8205" (calculated in Example 1)

Kc = 72π = 226.19

Hp = 38.5' (45' pole - 6.5' setting depth)

$$Mbn = 4 \left[\frac{(2 \cdot 21) + 34.8205}{226.19} \right] 38.5^2 = 2,014 \text{ ft-lbs.}$$

The designer's next step is to calculate the forces produced on a length and class pole for a set of NESC ice and wind conditions acting on a selected conductor wind span.

The *wind span* is the average of the lengths of the back span and the forward span of a given pole. Any pole in a line section must adequately support half of the back-span and half of the forward span. Example 3 illustrates the wind span calculation.

**Example 3:
Wind span calculation**

Calculate the wind span supported by Pole #2 below:

Figure 4

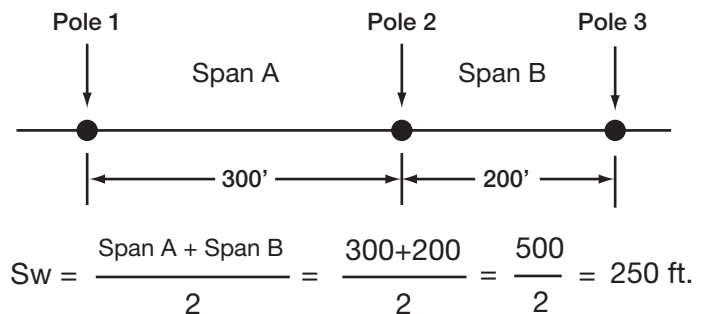

To determine the maximum transverse wind span for a given pole length and class with a set of specified conductors attached to a pole top assembly, the designer must calculate and sum the forces acting on the pole and wire with applied NESC strength and load factors.

Example 4 will work through the steps needed to calculate the total transverse load on the pole and wire and from those values, the maximum transverse wind span.

Table 6 lists the NESC load factors from NESC Table 253-1 and the strength factors from NESC Table 261-1. These values will be used to determine the maximum wind span for the 45'-4 Southern Pine.

Table 6

NESC load and strength factors for non-guyed wood poles		
<i>Load Factors</i>	<i>Grade B</i>	<i>Grade C</i>
Transverse wind at crossing	2.50	2.20
Transverse wind elsewhere	2.50	1.75
Transverse wire tension	1.65	1.30
Longitudinal at dead-ends	1.65	1.30
<i>Strength Factors</i>		
Wood poles	0.65	0.85

Example 4:
Evaluate the strength of 45'-4 wood pole for a 300-ft. wind span

Figure 5

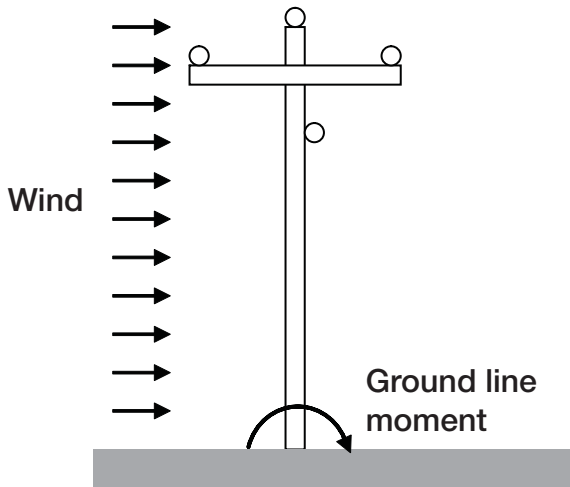

Wood pole = 45'-4 Southern Pine (SP) set 6.5-ft. deep
 Conductors = (3) 336 ACSR 18/1 (Merlin) primary with (1) 4/0 ACSR 6/1 (Penguin) neutral
 Wind span = 300-ft.
 Pole top assembly = RUS C1.11L
 NESC construction grade = C
 NESC loading district = Heavy

The problem is to determine if the 45'-4 SP pole will adequately support the 300' wind span of the above conductors at NESC Grade C construction with the applied ice and wind conditions of the heavy loading district. The line will cross over a communications line.

Step 1:

Calculate the wood pole resisting moment.

$$M_r = M_{rn}(F_s)$$

M_r = Resisting moment with applied NESC strength factor

M_{rn} = Natural resisting moment of a 45'-4 SP pole = 89,166 ft-lbs. (Table 5)

F_s = Strength factor for wood poles at Grade C (Table 6) = 0.85

$$M_r = 89,166 (0.85) = 75,791 \text{ ft-lbs.}$$

The reduced resisting moment (M_r) of the 45'-4 SP is 75,791 ft-lbs.

Step 2:

Calculate the moment (M_b) due to wind on the pole with the applied NESC load factor.

$$M_b = (M_{bn})(F_w)$$

M_b = Moment due to wind blowing on the pole with applied NESC load factor

M_{bn} = Natural (no load factor) bending moment due to wind = 2,014 ft-lbs. (Example 2)

F_w = NESC load factor, transverse wind at crossing, Grade C = 2.20 (Table 6)

$$M_b = (2,014)(2.20) = 4,430.8 = 4,431 \text{ ft-lbs.}$$

The bending moment due to wind with applied load factor on the 45'-4 SP is 4,431 ft-lbs.

Step 3:

Calculate the moment (M_c) due to wind blowing on the conductors.

$$M_c = \sum W_c(H_c)(F_w) = \text{Conductor wind moment with applied NESC load factor}$$

W_c = Transverse wind load per unit area of conductor for heavy loading (Table 3)

336 ACSR = 0.5613 lbs/ft.
 4/0 ACSR = 0.5210 lbs/ft.

H_c = Height of conductors above grade. Assume 38.5-ft. to pole top then calculate distance above grade for conductor based on C1.11L dimensions. Use 9-in. (0.75-ft.) for pin & insulator height.

AØ & CØ = 37.75-ft., BØ = 39.25-ft., Neutral = 35-ft.

F_w = NESC load factor for transverse wind at crossing, Grade C (Table 6) = 2.20

Figure 6
RUS C1.11L

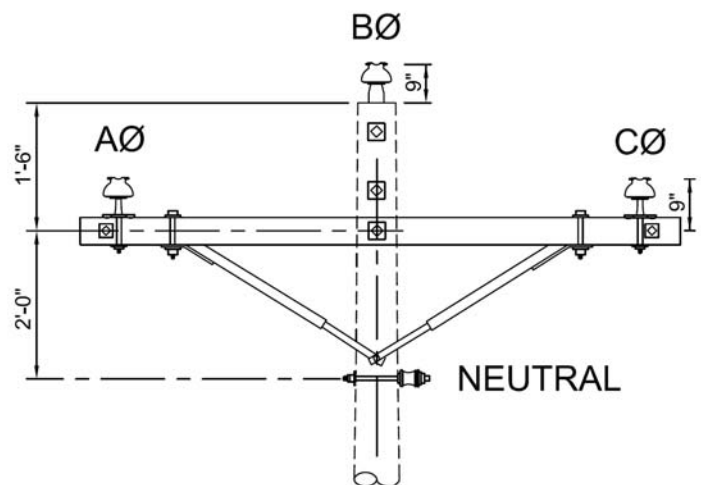

Wire	Wc (lbs/ft.)	Hc (ft.)	Fw	Mc (ft-lbs.)
AØ	0.5613	x 37.75	x 2.20 =	46.62
BØ	0.5613	x 39.25	x 2.20 =	48.47
CØ	0.5613	x 37.75	x 2.20 =	46.62
N	0.5210	x 35.00	x 2.20 =	40.12
			Mc (ft-lbs./ft.) =	181.83

The moment due to wind blowing on the ice-laden conductors is 181.83 ft-lbs./ft. for 1-ft. of each conductor tied to the pole top assembly.

Step 4:

Calculate the ground-line moment Mg.

- Mg = (Mc • Sw) + Mb
- Mg = Moment at ground-line produced by forces acting on the pole and conductors
- Mb = Moment due to wind on the pole = 4,431 ft-lbs. (Step 2)
- Mc = Moment due to wind on the conductors = 181.83 ft-lbs/ft. (Step 3)
- Sw = Wind span = 300' (Given)
- Mg = (181.83 • 300) + 4,431 = 58,980 ft-lbs.

Step 5:

Analyze the pole.

For a pole to adequately support the loads in the above example, it must have a resisting moment with applied NESC strength and load factors that exceeds the calculated ground-line moment of 58,980 ft-lbs. or Mr > Mg.

The calculated reduced resisting moment of the 45'-4 SP pole in Step 1 is 75,791 ft-lbs. Since 75,791 (Mr) is greater than 58,980 (Mg), the 45'-4 SP pole will adequately support the (3) 336 ACSR and (1) 4/0 ACSR conductors at Grade C crossing over a communications line in the heavy loading district for a wind span of 300 feet.

In fact, if the ground-line moment is subtracted from the ultimate resisting moment, the 45'-4 has strength to spare.

75,791 ft-lbs. minus 58,980 ft-lbs. equals 16,811 ft-lbs.

A smaller class pole could possibly be used to support the above conductors, or the spare strength may be needed to support future joint use communications cable.

Step 6:

Calculate the maximum wind span (Sm).

Since most line sections are composed of different length wind spans of the same type and size of conductors, it is often more convenient to calculate the maximum wind span for a specific pole

length and class, then design each wind span in the line section to be less than the calculated maximum wind span.

Calculate the maximum wind span (Sm) for the (3) 336 ACSR primary and (1) 4/0 conductors on a 45'- 4 SP tangent pole in heavy loading built to Grade C construction at a crossing. Rewrite the ground-line moment equation to solve for Sm and use the values for Mr, Mb, and Mc calculated in Example 4.

$$Sm = \frac{Mr - Mb}{Mc}$$

- Sm = Maximum wind span
- Mr = Resisting moment of the pole = 75,791 ft-lbs.
- Mb = Bending moment due to wind with applied load factor = 4,431 ft-lbs.
- Mc = Moment due to wind on the conductors with load factor = 181.83 ft-lbs./ft.

$$Sm = \frac{75,791 - 4,431}{181.83} = 392.45$$

The 45-ft. Class 4 pole will support the (3) 336 ACSR primary and (1) 4/0 neutral conductors in the heavy loading district built to NESC Grade C at a crossing over a communications line for a maximum wind span of 392-ft. This is for a tangent only.

In many cases, clearance above grade will control the span length and the actual wind span will be much shorter than the calculated maximum.

Caution: When the structure is designed to support a maximum wind span of specified power conductors, no strength is left for future communication cables or larger conductors.

Selecting a Non-Guyed Small Line Angle Pole Class

Occasionally, the line designer must select a pole with adequate strength to support a small line angle without a down guy. Per RUS guidelines, non-guyed line angle poles can be in the range up to and including 5°. The direction of critical loading for a non-guyed line angle pole is in the transverse direction.

In addition to the moments of wind on the iced conductors and wind on the pole, the moment caused by tension in the conductors must be calculated and applied to the pole to calculate the total ground-line moment. The following example will demonstrate how to select an adequate pole length and class to support a specified set of conductors.

Example 5: Evaluate the strength of a non-guyed line angle pole

Figure 7

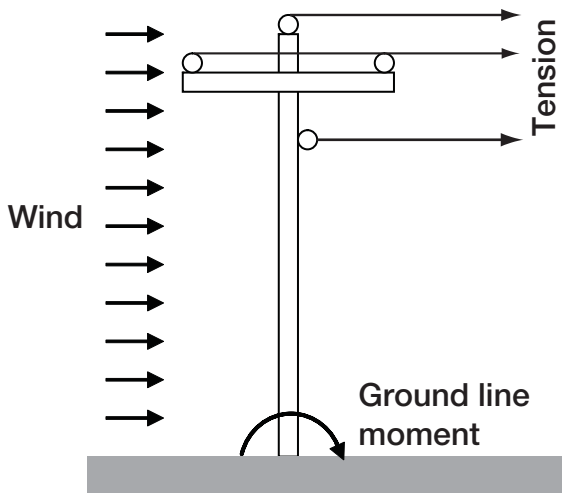

- Wood pole = 40'-3 Southern Pine (SP) set 6-ft. deep
- Conductors = (3) 1/0 ACSR 6/1 (Raven) primary with (1) 1/0 ACSR 6/1 (Raven) neutral
- Wind span = 200-ft.
- Line Angle = 4°
- Pole top assembly = RUS C2.21
- NESC construction grade = C
- NESC loading district = Light

The problem is to determine if the 40'-3 Southern Pine pole will adequately support the 200' wind span of the above conductors and the 4° line angle at NESC Grade C construction with the applied ice and wind conditions of the light loading district. The line is not crossing over another utility.

From ANSI 05.1, the 40'-3 Southern Pine pole top circumference equals 23 in. and the circumference 6-ft. from butt equals 36 in. Using the equations in Example 1 and 2, the natural resisting moment (M_{rn}) equals 98,537 ft-lbs. and the natural bending moment due to wind on the pole (M_{bn}) for light loading equals 3,772 ft-lbs.

Step 1:

Calculate the wood pole resisting moment.

- $M_r = M_{rn}(F_s)$
- M_r = Resisting moment with applied NESC strength factor
- M_{rn} = Natural ultimate resisting moment of a 40'-3 SP pole = 98,537 ft-lbs.
- F_s = Strength factor for wood poles at Grade C (Table 6) = 0.85
- $M_r = 98,537 (0.85) = 83,756$ ft-lbs.

Step 2:

Calculate the moment due to wind on the pole with the applied NESC load factor.

- $M_b = (M_{bn})(F_w)$
- M_b = Moment due to wind blowing on the pole with applied NESC load factor
- M_{bn} = Natural bending moment due to wind = 3,772 ft-lbs.
- F_w = NESC load factor, transverse wind elsewhere, Grade C = 1.75 (Table 6)
- $M_b = (3,772)(1.75) = 6,601$ ft-lbs.

The bending moment due to wind with applied load factor on the 40'-3 SP pole is 6,601 ft-lbs.

Step 3:

Calculate the moment due to wind blowing on the conductors.

- $M_c = \sum W_c(H_c)(F_w) =$ Conductor wind moment with applied NESC load factor (ft-lbs/ft.)
- W_c = Transverse wind load for 1/0 ACSR, light loading = 0.2985 lbs/ft. (Table 3)
- H_c = Height of conductors above grade. (see RUS specification C2.21) Assume 9-in. or 0.75-ft. for the height of the pin and insulator assembly RUS C2.21 framed on a 40-ft. pole set 6-ft. deep.
- $A\emptyset$ & $C\emptyset = 33.25$ -ft., $B\emptyset = 34.75$ -ft., Neutral = 30.5-ft.
- F_w = NESC load factor for transverse wind elsewhere, Grade C (Table 6) = 1.75

**Figure 8
RUS C2.21**

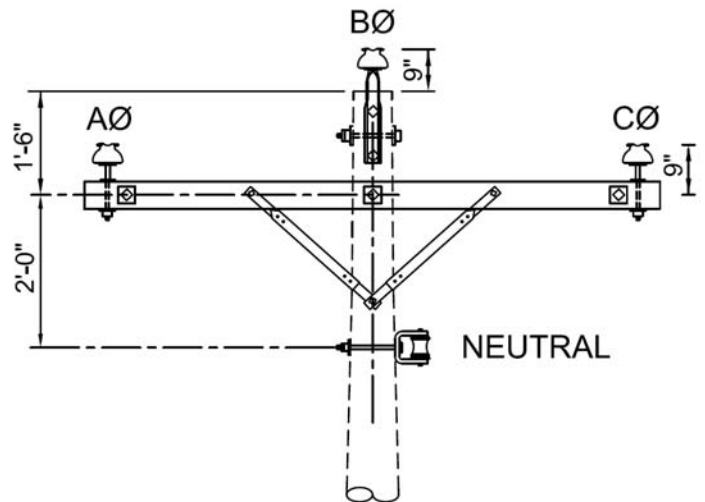

Wire	Wc (lbs/ft.)	Hc (ft.)	Fw	Mc (ft-lbs/ft.)
AØ	0.2985	x 33.25	x 1.75 =	17.37
BØ	0.2985	x 34.75	x 1.75 =	18.15
CØ	0.2985	x 33.25	x 1.75 =	17.37
N	0.2985	x 30.50	x 1.75 =	15.93
			Mc (ft-lbs/ft.) =	68.82

The moment due to wind blowing on the conductors is 68.82 ft-lbs/ft. for 1-ft. of each conductor tied to the pole top assembly.

Step 4:

Determine the moment due to tension in the conductors M_t .

The tension value used in this example is 50% of the rated tensile strength of 1/0 ACSR 6/1 conductor. Tensile strength of 1/0 = 4,380 lbs. (Table 3).
 $50\% = 0.5(4,380) = 2,190$ lbs.

The designer can choose to use the initial loaded tension value found in the company's sag and tension tables such as Sag10. This value may be significantly lower than the 50% of rated tensile strength depending on the loading district.

Caution: The designer must be confident that the construction crew is correctly tensioning the wire to the value shown in the sag and tension tables.

$$M_t = \sum [\text{Sine}(\theta/2) \cdot DT \cdot 2 \cdot H_c \cdot F_t]$$

M_t = Moment due to transverse wire tension (ft-lbs.)
 $\text{Sine}(\theta/2) = \text{Sine}(\text{Line Angle}/2) = (4^\circ/2) = \text{Sine}(2.0^\circ) = 0.0349$
 DT = Design tension (lbs.) = 2,190 lbs. for 1/0 ACSR at 50% of rated tensile strength
 H_c = Height in feet of conductors above grade (C2.21 on 40'-3 set 6-ft. deep)
 F_t = NESC load factor for transverse wire tension = 1.30 (Table 6)

Wire	Sine ($\theta/2$)	DT	Hc	Ft.	Mt (ft-lbs.)
AØ	0.0349	x 2,190	x 2 x 33.25	x 1.30 =	6,607
BØ	0.0349	x 2,190	x 2 x 34.75	x 1.30 =	6,906
CØ	0.0349	x 2,190	x 2 x 33.25	x 1.30 =	6,607
N	0.0349	x 2,190	x 2 x 30.50	x 1.30 =	6,061
			Mt (ft-lbs.) =		26,181

Step 5:

Calculate the ground-line moment.

$$M_g = (M_c \cdot S_w) + M_b + M_t$$

M_g = Ground-line moment
 $M_c = 68.82$ ft-lbs/ft. (Step 3)
 $S_w = 200'$ (Given)
 $M_b = 6,601$ ft-lbs. (Step 2)
 $M_t = 26,181$ ft-lbs. (Step 4)

$$M_g = (68.82 \cdot 200) + 6,601 + 26,181 = 46,546 \text{ ft-lbs.}$$

$$M_g = 46,546 \text{ ft-lbs.}$$

Step 6:

Compensate for deflection.

A non-guyed line angle pole will deflect under the strain of the applied moments. To compensate for this deflection, it is recommended that the ground-line moment (M_g) be increased by a deflection factor before evaluating the pole class.

The deflection factor is chosen by the designer based on his or her experience. Twenty percent will be used for this example. Some designers may choose a higher value based on local conditions.

$$M_g' = M_g (1.20)$$

$$M_g' = 46,546 (1.20) = 55,855 \text{ lbs.}$$

Step 7:

Evaluate the strength of the 40-ft. Class 3 pole.

The calculated reduced ultimate resisting moment of the 40'-3 SP in Step 1 is 83,756 ft-lbs. Since 83,756 (M_r) is greater than 55,855 (M_g'), the 40'-3 SP pole will adequately support the structure for the specified loading conditions.

Like the tangent pole evaluation, it is often more useful to calculate the maximum wind span for a specific pole length and class and then design each wind span in the line section of non-guyed line angle poles to be less than the calculated maximum wind span. This can be done by rewriting the ground-line equation in Step 5 including the deflection compensation factor to solve for the wind span (S_m).

Step 8:

Calculate the maximum wind span with compensation for deflection for the (4) 1/0 ACSR conductors on the 40'-3 SP non-guyed line angle pole in Example 5.

$$S_m = \frac{\left(\frac{M_r}{1.20} \right) - M_b - M_t}{M_c}$$

- S_m = Maximum wind span
 M_r = Resisting moment = 83,756 ft-lbs. (Step 1)
 M_b = Bending moment due to wind on pole = 6,601 ft-lbs. (Step 2)
 M_c = Moment due to wind on the conductors = 68.82 ft-lbs./ft. (Step 3)
 M_t = Moment due to transverse wire tension = 26,181.44 ft-lbs. (Step 4)
1.20 = Deflection factor

$$S_m = \frac{\left(\frac{83,756}{1.20} \right) - 6,601 - 26,181}{68.82} = 538 \text{ ft.}$$

The 40'-3 non-guyed line angle pole will adequately support a 538-ft. maximum wind span for the specified design conditions.

Foundation

Proper embedment of the non-guyed pole is extremely important for good construction. Backfill the pole hole with good soil and tamp extra hard.

The old rule of two men tamping and one man shoveling holds true. In poor soils, it may be necessary to backfill the hole with gravel and set the pole deeper at 10% of its length plus 4-ft.

Deeper setting depths will change the ground-line circumference and the height above grade of the conductors. The ground-line moment must be re-calculated and height of the conductors above grade adjusted in the equations for the new values if the pole is set deeper in the ground.

Valuable Considerations for Using Wood Poles

Basic Impulse Insulation Level (BIL)

The Basic Impulse Insulation Level or BIL defines the ability of a structure to withstand a lightning impulse. A Basic Impulse Insulation Level of less than 300 kV can produce lightning flashovers when lightning strikes near the electric distribution line.

A BIL equal to or greater than 300 kV (dry flashover) can be achieved on wood poles using standard pole-top assemblies rated for the operating voltage. The wood provides the additional insulation needed to achieve the required BIL.

On metal or concrete poles, fiberglass links or higher voltage insulators must be added to standard pole-top assembly hardware to achieve the same BIL as wood poles. The phase conductors, insulators and neutral conductor in a three-phase steel or concrete pole distribution line are all connected by a conductor. In a wood pole distribution line, they are connected by a wood insulator.

For areas of high lightning incidence, lightning arrestors should be installed approximately every 1,200-ft. along the line and at dead-ends. This will augment the natural insulation of the wood and minimize nuisance recloser operations and fuse blowing. This is more important for steel or concrete poles because of their essentially zero BIL.

Raptor Protection

In many areas of the U.S., utilities must provide raptor protection to comply with federal regulations. Wood pole and crossarm construction offers a distinct advantage because of the natural insulating properties of wood.

For most raptors, including eagles, electrocution can be effectively prevented using a 10-ft. wood crossarm mounted 12 to 18 in. below the pole top. This will provide the recommended 60-in. spacing required for raptor protection.

Steel or concrete poles can act as a grounding conductor, thus decreasing the phase to ground clearance for raptors.

It is recommended that 24-in. fiberglass pole-top pins, vinyl pole wraps, perch guards and wood or fiberglass crossarms be installed on steel or concrete poles to achieve adequate raptor protection.

As can be seen, standard wood pole crossarm construction can reduce raptor electrocution without addition of special assemblies or perch guards. Wood provides a humane and economic advantage in protecting raptors.

Installation

Wood poles are easier to handle, store and work with than alternative materials. They can be stacked in bundles in the pole yard without cribbing.

Wood poles can be loaded onto a bare steel pole trailer using metal cables and standard rigging. No provision is needed to cushion the trailer rails or protect the exterior pole from scratches or scrapes.

Standard utility digger-derrick trucks are adequate to handle and set most wood poles up to 70-ft. in length.

In most cases, wood poles can be backfilled with the same material that was excavated from the pole hole. For additional strength, gravel backfill may be used to provide a more substantial foundation. Tamping can be done with hydraulic or hand tamps without worry over damaging the exterior surface of the pole.

The larger butt section and rougher texture of wood provides substantial adhesion to the embedment soil. The smaller diameter and slicker surface of a directly embedded light steel pole offers little resistance to leaning unless special care is taken to adequately tamp the embedment material.

Holes are easily bored in wood poles with conventional drills for any combination of assemblies. Newly bored holes can easily be field treated by swabbing with a preservative.

Standard guy attachment hardware using lag bolts or cleats to anchor the lower end of the attachment to provide strength and prevent guy attachment rotation can be used on wood poles.

Steel or concrete poles require smooth sided guy attachments with two machine bolts. No cleats can be present on the side of the pole eye plate next to the pole face or a lag bolt used to anchor the attachment to an alternative pole material.

A significant number of poles on a utility's system can be worked more efficiently by a climbing lineman than with a bucket truck. Wood poles are easily climbed using traditional climbing tools.

No special pole steps must be included in the design or purchase of a wood pole. This feature is not only beneficial for remote areas but also for yards and back lot lines of subdivisions that are not readily accessible to standard aerial lifts.

Duty Cycle

How long will wood poles last in service is a common and important question. With a continuing inspection and maintenance program, it has been shown that pole service life can reach 75 years or beyond.

Steel and concrete claim life spans of 80 years, but the products have not been used long enough in direct burial installations to fully evaluate the impact of age and corrosion.

The duty cycle, or service life of a pole depends largely on factors other than the condition of the pole.

Often, a pole is replaced not because it has deteriorated beyond its inherent strength to support the conductors, but because a line is upgraded, roads are widened, or land is developed.

A significant number of poles are replaced due to these factors rather than to deterioration. These poles can be reused at other locations or recycled for non-utility applications.

In fast growth areas with short duty cycles caused by frequent upgrades, development or road widening, the lower cost of wood has a distinct economic advantage over the alternatives.

*For more information on wood pole service life, see the NAWPC Technical Bulletin **Estimated Service Life of Wood Poles** in the Online Technical Library at www.woodpoles.org.*

Flexibility

Wood poles are very flexible and can survive many adverse conditions caused by nature. When trees fall on conductors and guy wires, the wood pole will deflect significantly before breaking. Many times, the trees can be cut off the line and the pole will spring back into position.

The wood pole is forgiving to the change in conductor tension between spans. On very rigid poles such as concrete, the change in conductor tension brought about by expansion and contraction due to temperature change can twist crossarms and bend pins. The wood pole tends to flex with the change in conductor tension and is not likely to damage the hardware.

Environmental Benefits

One of the most overlooked advantages of wood utility poles over other materials is its many environmental benefits. Utilities today are considering their carbon footprint and the use of wood poles offers great opportunities to reduce their overall environmental impact.

Trees sequester carbon from the atmosphere as they grow and, once harvested and converted into poles, they lock the carbon in place. In all, there are thousands of tons of carbon stored in the system of preserved wood poles across North America. No other material offers this environmental advantage.

The longevity of preservative treated poles also contributes to wood's green benefits. Over the course of the many decades a wood pole is in service, a new tree easily can be grown to provide a replacement.

Modern forestry practice and reforestation activities have made American forests among the most sustainable in the world. Each year, some 1.6 billion trees are planted in the U.S., or about six trees for every one used.

Compared to other materials, wood poles are much kinder to the planet when considering the full impact of production and use. Independent, science-based life cycle assessments, or LCAs, conclude that preservative treated wood utility poles use less energy and resources, offset fossil fuel use and have a reduced environmental impact when compared to concrete, steel and fiber-reinforced composite utility poles.

*For more information on the environmental benefits of wood poles vs. alternative materials, see the **Summary Report on LCA of Utility Poles** in the NAWPC Online Technical Library at www.woodpoles.org.*

Conclusion

Despite intense promotion by alternative materials and developments in engineered products, the fact is undisputable that now and for years to come, treated wood remains the best all-around product for most utility applications.

It is raptor friendly, easy to install, naturally insulating and has a long duty cycle. These factors make the treated wood pole a leader in safety, reliability and efficiency.

The key is to understand the design and application of wood poles.

For more resources on wood poles, go to the NAWPC website at www.woodpoles.org.

For more on wood pole design and application, access the Hi-Line Engineering website at www.hi-line-engineering.com for a schedule of nationwide seminars.

Reference

National Electrical Safety Code, 2017 Edition. Institute of Electrical and Electronics Engineers, 3 Park Avenue, New York, NY 10016-5997 USA

ANSI O5.1-2017. American National Standard for Wood Utility Products. American Wood Protection Association, PO Box 36174, Birmingham, AL 35236

ANSI O5.1-2015. American National Standard for Wood Utility Products. American Wood Protection Association, PO Box 36174, Birmingham, AL 35236

RUS Bulletin 1728F-804, Specifications and Drawings for 12.47/7.2 kV Line Construction. United States Department of Agriculture, Rural Utilities Service

Disclaimer - *The North American Wood Pole Council and its member organizations believe the information contained in this document to be based on up-to-date scientific and economic information and is intended for general informational purposes. In furnishing this information, NAWPC and GDS Associates DBA Hi-Line Engineering make no warranty or representation, either expressed or implied, as to the reliability or accuracy of such information; nor does NAWPC and GDS Associates DBA Hi-Line Engineering assume any liability resulting from use of or reliance upon the information by any party. This document should not be construed as a specific endorsement or warranty, direct or implied, of treated wood products or preservatives, in terms of performance, environmental impact or safety. The information contained herein should not be construed as a recommendation to violate any federal, provincial, state or municipal law, rule or regulation, and any party using or producing pressure treated wood products should review all such laws, rules or regulations prior to using or producing preservative treated wood products.*



North American Wood Pole Council